



**Apexlift[®] Stella
Stand Assist Lift
OWNER'S MANUAL**

IMPORTANT NOTES

Please pay attention to the important information regarding the care, maintenance, and operation of the ApexLift *Stella* in this manual.

Please read the instructions carefully before assembling the lift, or attempting to lift any patient with the device.

Always keep the Owner's Manual available with the lift.

Remember to complete the warranty registration card and mail it back.

SAFETY PRECAUTIONS

The ApexLift Stella stand assist lift allows a caregiver to lift and transfer a patient safely with minimum physical effort. Before attempting to lift anyone, one should practice operating the lift and explain to the patient the lifting procedures.

Arrange all necessary items (e.g. lift, sling, commode chair or wheelchair) properly for a smooth procedure.

- Special care must be taken with patients who cannot provide assistance while being lifted. (i.e. patients who are comatose, spastic, agitated or otherwise severely handicapped).
- The ApexLift *Stella* should be used solely for transferring a patient from one object (beds, bathtubs, toilets, etc.) to another. **The lift should not be used for transporting or moving any patient from one location to another location.**
- During lifting or lowering, whenever possible, always keep lift base widened.
- Always keep the patient being lifted centered over the base and facing the caregiver operating the lifter.
- Do not roll casters over any object while the user is in the sling.
- Use only ApexLift slings specially designed for ApexLift Stella. Do not use slings manufactured by other company on ApexLift Stella. Apex Dynamics Healthcare Products, LLC. is not responsible for any consequence resulting from using non-ApexLift products.
- Do not put anything (e.g. cushion, pad, etc.....) between the user and the sling. This may cause user to slide out of the sling and cause injury.
- Use only ApexLift parts or components. Apex Dynamics Healthcare Products, LLC. is not responsible for any consequence resulting from using non-ApexLift parts and components.
- Service and repair of the ApexLift Stella should be performed by Apex Dynamics Healthcare Products, LLC. or its authorized dealer. Apex Dynamics Healthcare Products, LLC. is not responsible for any consequence resulting from any unauthorized service or repair.
- Do not lift over the maximum weight allowed.

Warning!

Do not attempt to transfer a patient without prior approval of the person's nurse. Also, do not transfer without having studied the instructions and performed several practices in operating the product. Together (with the patient's doctor, nurse, or medical attendant) select a sling that is both practical and comfortable. The sling selected should be one that serves the needs of the patient, while providing the patient with optimal safety. Never interfere with the lift, unless instructed by the attendant. Have a doctor, nurse, or medical attendant (experienced in the use of the ApexLift Stella) presented during the first few times the lift is used to transfer a new user.

FEATURES

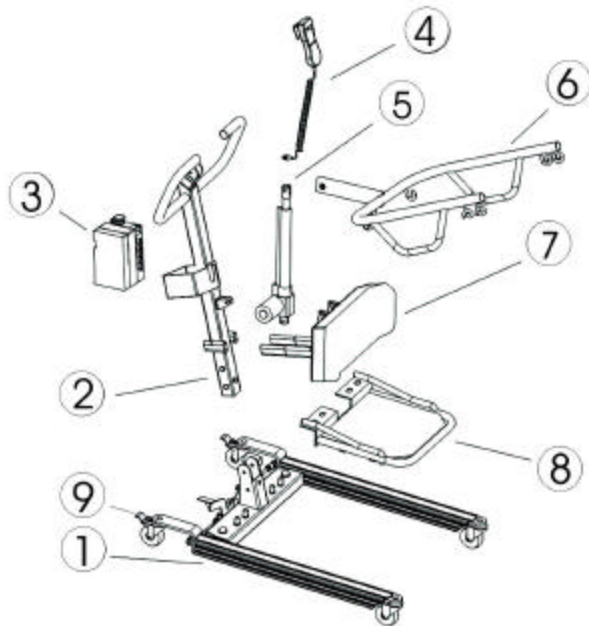

- ① Base-
- ② Mast-
- ③ Control Box-
- ④ Pendant-
- ⑤ Actuator-
- ⑥ Lifting Boom-
- ⑦ Kneepad Assembly-
- ⑧ Footrest-
- ⑨ Brake

ASSEMBLY INSTRUCTIONS

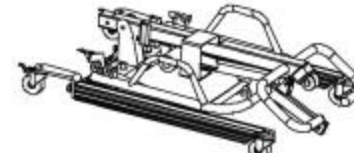

1. Open the box and take lift out.
2. Unscrew nuts and bolts at top and bottom of the mast.



3. With one hand on the mast and another on the boom, stand the mast up.
4. Put bolts through the bottom two holes at the base of the mast and hand tight them.

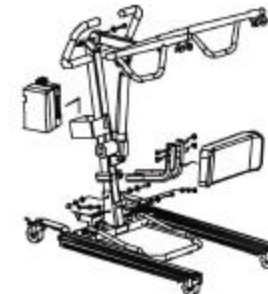

5. Attach boom to mast and hand tight bolt and nut.
6. Attach the L-shaped arms to back of the kneepad. For desired height of the kneepad, use proper holes on the L-shaped arms.
7. Attach kneepad assembly to the mast.
8. Attach actuator and pendant to the control box.
9. Tighten all nuts.
10. Make sure the lift is sturdy before use .

OPERATION INSTRUCTIONS

Preparation Before Lifting

1. Turn on the power by twisting the RED RESET BUTTON clockwise.
2. Press the UP or DOWN button on the hand control once. Check if the battery indicator lights are on. To proceed with lifting, make sure there is at least one green light. Batteries are fully charged when three (3) green lights are shown.
3. After the battery indicator lights went out, push the UP button and the DOWN button on the hand control and ensure that the lift is operating correctly.
4. Position of the base of lift around or under the object.
5. Widen the base and engage the caster bakes.

Fitting ApexLift Stand Assist Sling

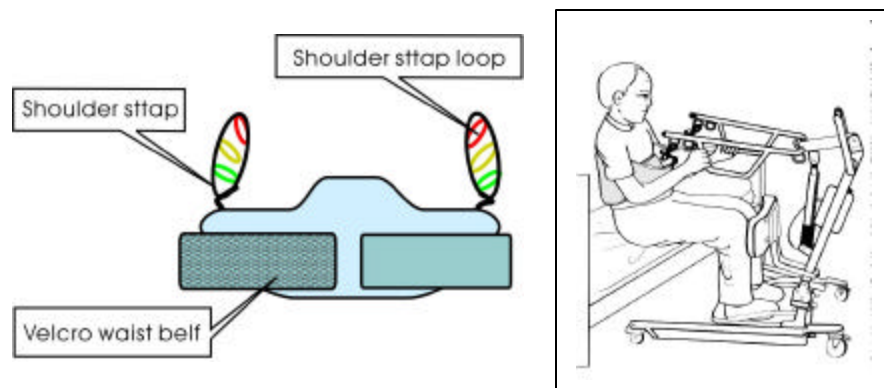

Safety Note: The ApexLift Stella stand assist sling is not suitable for patients who have involuntary movements, or patients with limited postural control.

1. Position the patient in a sitting position.
2. Slide the sling down patient's back to lumbar position.
3. Draw the shoulder straps to the front of the patient close to the chest.
4. Draw the waist belt around patient's waist and press together to fasten.
5. Attach the shoulder straps to the hooks.

Lift and Transfer From Bed



1. Fit sling as described in "Fitting ApexLift Stella Stand Assist Sling".
2. Push lift towards patient. Open the base of the lift. Apply the brakes in both rear casters.
3. Position patient's feet on the foot platform and knees against the knee pad.
4. Attached the sling straps to the hooks.
5. Have the patient's hands holding the handles. For patient's who cannot hold the handles, have them hold their arms around the chest.
6. Press the "UP" button on the hand control.
7. Before the patient's body is lifted from the bed, stop and make sure the sling is secured and patient's knees are against the knee pad.
8. The patient should be comfortable with the pressure under the arms. If not, adjust the sling and try another loop option to release pressure.
9. Press the "UP" button until the patient's body is completely left the bed.
10. Transfer to another object can be done at this position without the patient attending a full standing position.
11. Release the brakes, close the base, and pull the lift away from the bed.
12. Lower the patient to the object intended.
13. To lift patient in a standing position, continue to lift until the patient's knees are locked in a standing position.
14. At the standing position, patient's knees may move away from the knee pad.
15. Release the brakes, close the base, and pull the lift away from the bed.
16. Lower the patient to the object intended.
17. Reverse the above procedures when lowering the patient to the bed.

Lift and Transfer From Wheelchair



1. Fit sling as described in "Fitting ApexLift Stand Assist Sling".
2. Push lift towards patient. Open the base of the lift to go around the chair. Apply the brakes in both rear casters.
3. Position patient's feet on the foot platform and knees against the knee pad.
4. Attached the sling straps to the hooks.
5. Have the patient's hands holding the handles. For patients who cannot hold the handles, have them hold their arms around the chest.
6. Press the "UP" button on the hand control.
7. Before the patient's body is lifted from the chair, stop and make sure the sling is secured and patient's knees are against the knee pad.
8. The patient should be comfortable with the pressure under the arms. If not, adjust the sling and try another loop option to release pressure.
9. Press the "UP" button until the patient's body is completely left the chair.
10. Transfer to another object can be done at this position without the patient attending a full standing position.
11. Release the brakes, close the base, and pull the lift away from the bed.
12. Lower the patient to the object intended.



13. To lift patient in a standing position, continue to lift until the patient's knees are locked in a standing position.
14. At the standing position, patient's knees may move away from the knee pad.
15. Release the brakes, close the base, and pull the lift away from the bed.
16. Lower the patient to the object intended.
17. Reverse the above procedures when lowering the patient to the bed.

Checking The Battery

1. Check batteries by pressing the Battery Testing Button (blue circle with a battery sign) on the control box.
2. Batteries are fully charged when all lights on the Battery Indicator are "ON".
3. Charge batteries when Indicator shown only one "GREEN" light.
4. Do not use the lift when no "GREEN" light is shown. Charge the batteries immediately.
5. Replace batteries when frequent charging is needed.

Know What The Battery Indicator Lights Are Telling You:

RED	AMBER	GREEN	GREEN	GREEN	
ON	ON	ON	ON	ON	FULLY CHARGED
ON	ON	ON	OFF	OFF	NEED CHARGE
ON	ON / OFF	OFF	OFF	OFF	CHARGE IMMEDIATELY. DON'T USE THE LIFT
OFF	OFF	OFF	OFF	OFF	BAD BATTERIES OR BAD CONNECTION

Warning Buzzers

The control box has a buzzer that provides you with information on the status of the batteries and the lift. To stop the buzzer, push down the RESET button or press the Battery Indicator.

BUZZER TYPE	INDICATION	NOTE
2 beeps/sec	Low Battery (red/amber lights on)	Charge batteries immediately.
3 beeps/sec	Low Battery (red light on)	Charge batteries immediately.
6 beeps/sec	Very Low Battery (no light on)	Charge batteries immediately.
3 beeps every other second	Bad Battery (no light on)	Replace batteries.
3 long beeps	Overloaded. Batteries are charged but lift does not lift.	Exceeded maximum load capacity.

Charging The Batteries

1. Ensure the power is switched "ON" (the red "RESET" button should be up).
2. Insert charging plug into charging port on the control box.
3. Plug charger to power supply.
4. All lights of battery indicator should be "ON" while charging.

5. It takes approximately 2-3 hours to fully charge the batteries from one green light.
6. It takes approximately 7-9 hours to fully charge the batteries from the red light.
7. Do not leave the batteries on charging for an extensive period of time. This will shorten the life of the batteries.
8. Do not let the batteries run down to the last red light. This might shorten the life of the batteries or damage the batteries.
9. Unplug the charger first before using the lift. **THE APEXLIFT STELLA WILL NOT OPERATE WHILE CHARGING.**

Important Notes On Charging

1. Push lift to charging location and charge the batteries with the charger provided. Avoid unplug hand control and motor from control box. Frequent plug/unplug of the hand control and motor into/from the control box may damage the control box.
2. Do not charge batteries over 12 hours.

MAINTENANCE AND INSPECTION INSTRUCTIONS

- The operator of the lift shall inspect the ApexLift Stella before each use. Check all bolts for tightness. Make sure the base can be easily widened, and that all lift parts are in place. Make sure that casters can be turned freely, and that caster brakes can be engaged. Make certain all necessary items (i.e. slings, and wheelchairs, etc.) are ready for use.
- At least once a month, the lift should be thoroughly inspected by a person qualified to recognize any signs of wear and tear, and looseness of bolts or parts. Replace any worn parts immediately.
- To lubricate, put a drop of oil on the following points when the ApexLift Stella is placed into service and every month thereafter. Top of Mast, Spreader Hinge, and Caster Axles.

Table of Maintenance Schedule:

Item	In the Beginning	Monthly	Every 3 month
1. Boom & Spreader Bar : <ul style="list-style-type: none"> Check connections between 1) Boom and Spreader Bar 2) Boom and Mast for improper connection, looseness, or wear. Check the Boom for bending and deflection. 	√ √	√ √	
2. The Mast : <ul style="list-style-type: none"> Check Mast for bending or deflection. 	√	√	
3. The Base & Foot Paddle : <ul style="list-style-type: none"> Check bolts and nuts for looseness. Check casters and bolts for tightness. Check rubber parts of the casters for deflection. Apply grease to caster ball bearings if needed. Check welding joints for rust and crack. 	√ √ √	√ √	√ √
4. Cleaning : <ul style="list-style-type: none"> Any time needed. 			√
5. Actuator & Control Box: <ul style="list-style-type: none"> Make sure the control box is firmly affixed to the mast. Make sure the pins are firmly affixed the actuator to the Boom and the Mast. Make sure the connecting cable of actuator and control box is not loose. Make sure that the Battery Indicator shows at least 2 green LED prior to use. 	√ √ √ √	√ √ √	
6. Slings & Sling Hardware: <ul style="list-style-type: none"> Check sling for wear. Check sling hardware before use. 	√ √	√ √	

TROUBLE SHOOTING

<i>Symptom:</i>	<i>Corrections:</i>
Cannot lift patient up and battery indicator shows no GREEN light.	<ul style="list-style-type: none"> Charge the batteries.
Lift does not work and the battery indicator shows full charge.	<ul style="list-style-type: none"> Check connection between the actuator and the control box. Check connection between Pendant & control box.
Lift does not work and the battery indicator shows no light.	<ul style="list-style-type: none"> Make sure the emergency stop button is released. Check connection of the batteries in control box.
Stop-and-Run while lifting or lowering patient.	<ul style="list-style-type: none"> Check socket for pendant plug-in. Check pendant cable.
Battery Indicator shows no light when charger is connected to power supply	<ul style="list-style-type: none"> Check the emergency stop button is released. Check charger plug for damage. Check charger cable for damage.
Lift does not work. Battery indicator shows full charge. Notice "click" sound from control box when UP or DOWN button on hand control was pressed.	<ul style="list-style-type: none"> Actuator problem.

If there is any problem you could not solve, please contact the dealer for assistance.

ACCESSORIES

Apexlift Toileting Sling

The **ApexLift** Toileting Sling can be used with the **ApexLift Stella** to lift a patient in a sitting position. When in use the ApexLift Toileting Sling supports the client under the thighs and across the mid-back area.

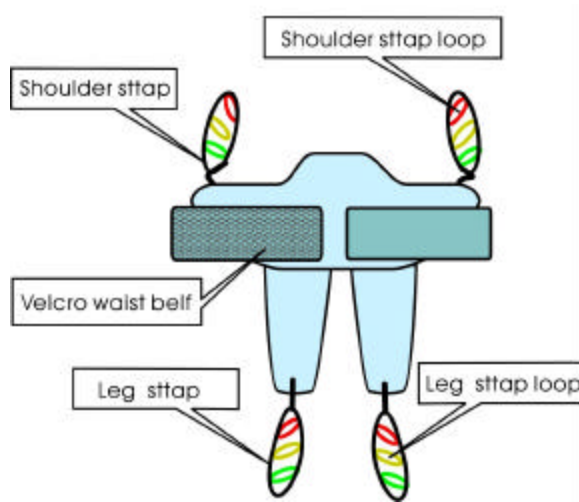

Safety Note: The ApexLift Toileting Sling is not suitable for patients who have involuntary movements, or patients with limited postural control.

Fitting The ApexLift Toileting Sling

1. Slide the sling down patients back to lumbar position.
2. Draw shoulder straps under the arms and around the chest into the front.
3. Draw Velcro waist belt around waist and press together to fasten.
4. Draw each leg support under the thigh.
5. Crisscross leg straps by feeding one of the leg straps through the other strap.
6. Attach shoulder straps to hooks in upper ends of the lifting arms.
7. Attach leg straps to hooks in the lower ends of the lifting arms.

